

MODULAR METHODOLOGY FOR SENSING AND CONTROL IN RESIN TRANSFER MOLDING



J. M. Lawrence (PhDME), M. Devillard (MSME), and S. G. Advani

University of Delaware • Center for Composite Materials • Department of Mechanical Engineering

RTM WORKSTATION TO AUTOMATE AND MODULARIZE RTM PROCESSING

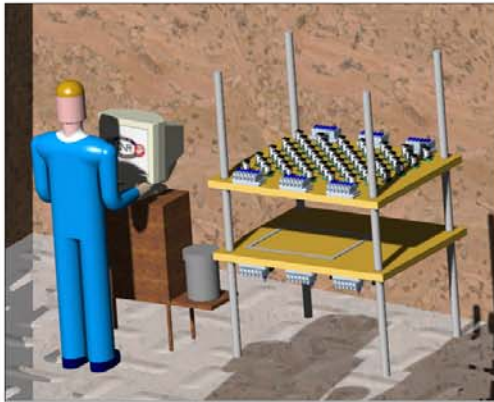

MODULAR MOLDING

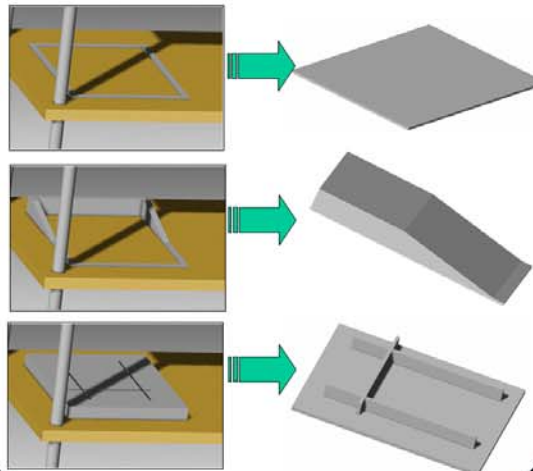

CHANNEL-BASED INJECTION

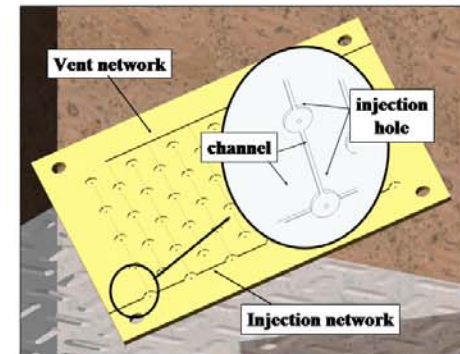

PISTON TO INDIVIDUALLY CONTROL GATES AND VENTS

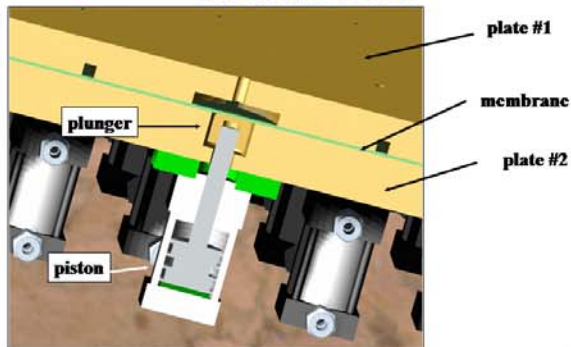

WHEN INDIVIDUAL PISTON IS RAISED, THE FLUID CAN STILL FLOW TO LATER GATES

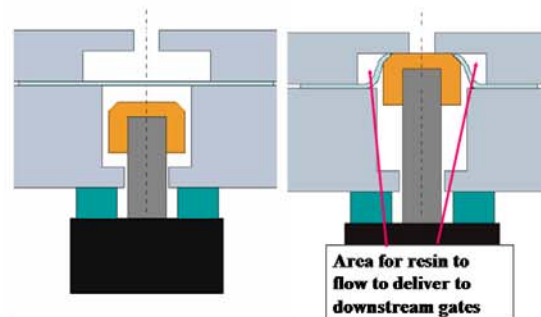

CONCLUSIONS

- An RTM Workstation could greatly reduce the tooling costs and aid in providing control to the resin filling stage
- A new resin delivery system can aid in reducing manufacturing waste in time and materials
- A prototype of the system shows the concept to be valid

ACKNOWLEDGEMENTS

This work is supported by the Office of Naval Research through the Advanced Materials Intelligent Processing Center program.

Part-to-Part Operation of the RTM Workstation

The mold system is ready to start with the first part



The preform is loaded into the mold

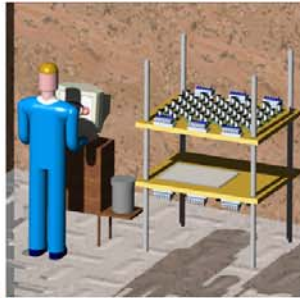

The mold is closed, the resin is injected and allowed to cure

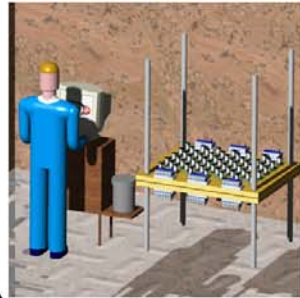

The mold is opened, revealing the filled part

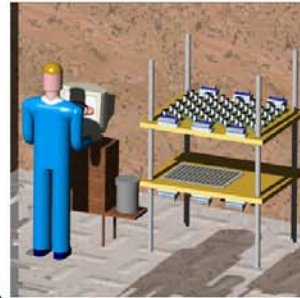

The part is demolded ...

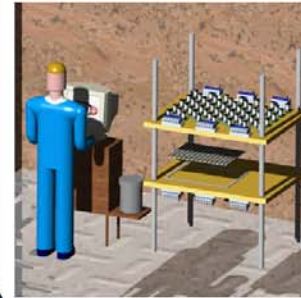

... and removed from the mold



The plate systems are separated revealing the resin chunks

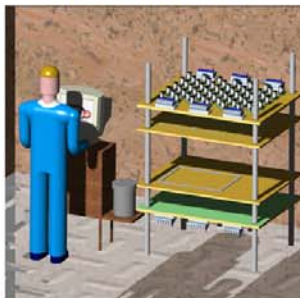

The resin chunks are demolded ...

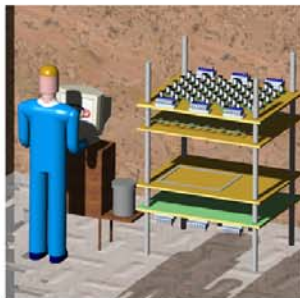

... and removed from the mold

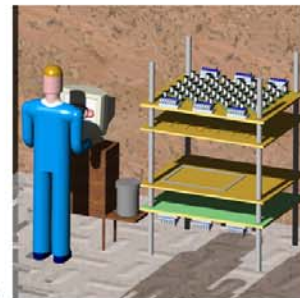

Finally, the mold is prepared by applying release agent

